



QuEENet

Quantum Enhanced Expressive Network

Shashank Bayal^{1*}

Rushikesh Govind Dawane^{1*}

Komal^{1*}

Santosh Kumar Vipparthi¹

Subrahmanyam Murala²

1: Indian Institute of Technology Ropar, INDIA

2: Trinity College Dublin, IRELAND



Motivation

- To design a parameterized quantum circuit that enhances performance of hybrid quantum architecture.
- The focus is achieving competitive performance with lesser classical parameters by utilizing quantum circuits.

Novelty

- Improved performance
- Better expressibility
- Lesser qubit count than other hybrid quantum baseline models
- Inclusion of Non-Clifford gates for quantum advantage

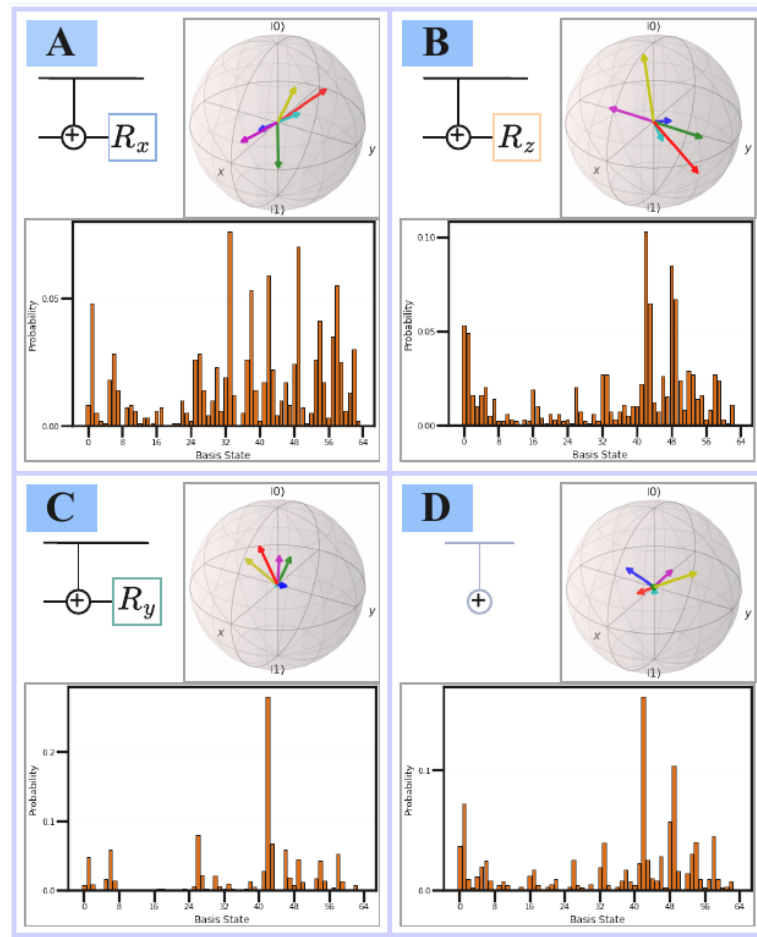

Hybrid Quantum Architecture

- Hybrid architecture combines classical and quantum computing components for solving machine learning problems.
- In this architecture the classical computer handle data pre-processing, optimization, and pre-processing. On the other hand, quantum processor executes specific subroutines that benefit from quantum advantages.

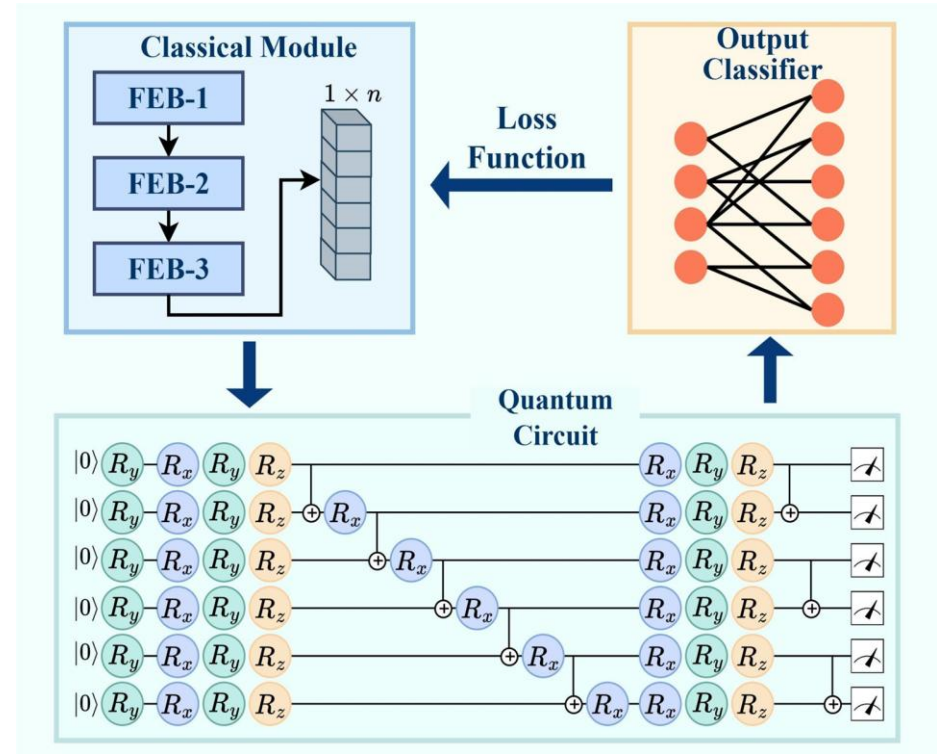

Classical Module

- Classical module performs the task of feature extraction and dimensionality reduction.
- Utilizes convolutions operation for feature extraction.
- For gradient stability batch normalization is applied.

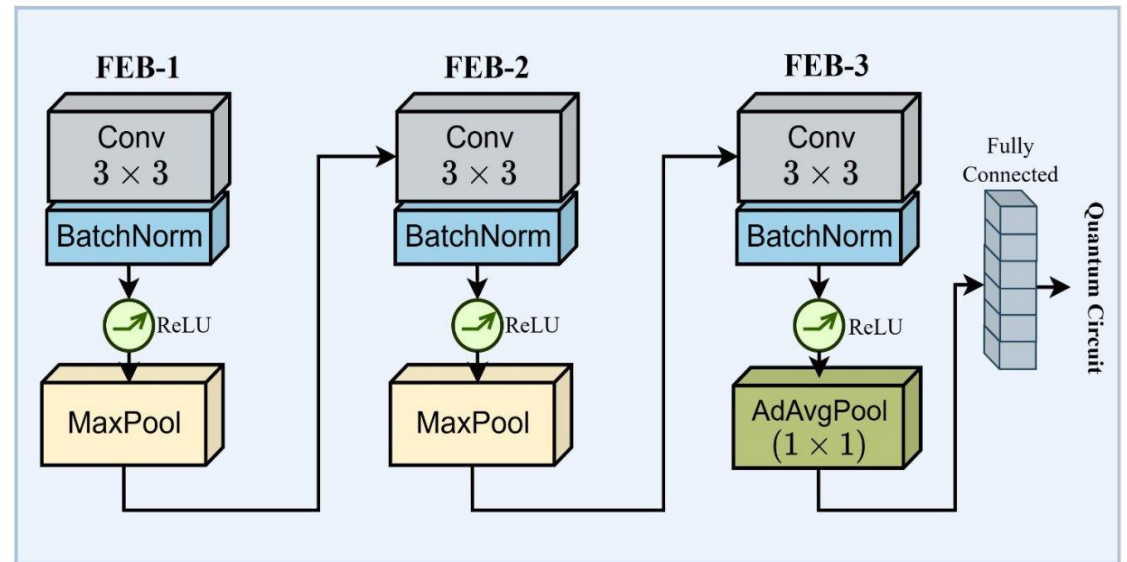

Quantum Module

- The module consists of two quantum circuits.
- The features extracted are embedded in qubits of the quantum circuit using angle embedding.
- Then qubit information is transformed based on the quantum circuit gates operations.
- The circuits consists of parameterized rotational gates , CNOT gates and non-Clifford gates.
- The outcome is measured in terms of 128 probabilities (64 from each quantum circuit).

Architecture

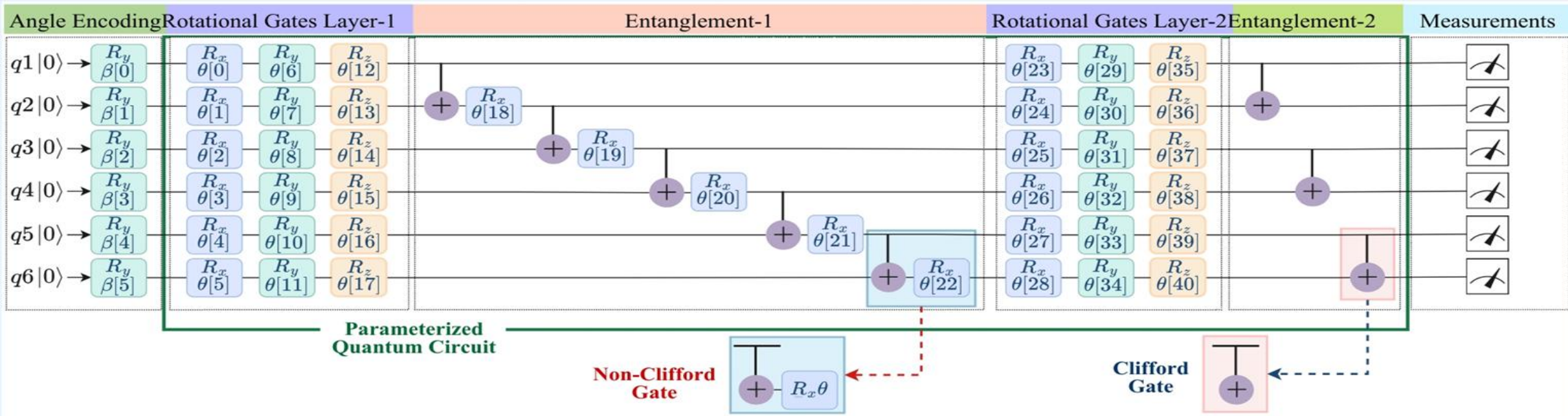

Notations:

R_x R_x Rotational Gate
 R_y R_y Rotational Gate
 R_z R_z Rotational Gate
 CNOT Gate
 Measurements
 θ : Trainable parameter
 $q|0\rangle$: qubit (0 state initialization)
 β : Input parameter

Clifford vs Non-Clifford Gates

- Clifford gates don't provide quantum advantage. Circuits with Clifford-only gates remain classically simulable under the Gottesman-Knill theorem, limiting their computational power despite enabling entanglement.
- On the other hand, non-Clifford gates allows parameterized quantum circuit to explore a denser region of the Hilbert space.

Expressibility

- Expressibility quantifies the capability of a quantum circuit to represent an arbitrary quantum state in Hilbert space.
- High expressibility quantum circuits may suffer from trainability issues like Barren plateaus.

1st Layer	Entanglement-1	3rd Layer	Entanglement-2	Expressibility
RX RY RZ	CNOT + RZ	RX RY RZ	CNOT	0.078
RX RY RZ	CNOT + RX	RX RY RZ	CNOT	0.1
RX RY RZ	CNOT	RX RY RZ	CNOT	0.31

Results

1. Remote Sensing datasets

Method	Parameters	Fog1 (%)	Fog2(%)
Lw-fire (1)	2.1 M	96.87	84.79
FireClassNet (2)	0.66 M	92.90	86.14
FireDetector (3)	0.65 M	97.60	84.63
MAIN (4)	0.7 M	97.68	84.61
Proposed(Cnot+Rz)	0.085M	99.28	93.03
Proposed(Cnot+Rx)	0.085M	99.32	92.39

Results

2. Benchmarking classification datasets (Cifar10 and Fashion-Mnist)

Method	Parameters	Cifar10 (%)
Arsenii et al (5)	0.08 M	82.78
HQViT (6)	15.7 M	33.41
Proposed(Cnot+Rx)	0.085M	85.55
Proposed(Cnot+Rz)	0.085M	85.73

Method	Parameters	F-Mnist (%)
Lw-fire (1)	2.1 M	92.00
LHQNN (7)	1.6 M	90.17
Proposed(Cnot+Rx)	0.085M	92.59
Proposed(Cnot+Rz)	0.085M	92.70

Results

3. Benchmarking datasets (Mnist and Medical-Mnist)

Method	Parameters	Mnist (%)
HQNN [8]	0.4M	99.21
CAE-QNN [9]	0.09M	89.80
Proposed(Cnot+Rx)	0.085M	99.08
Proposed(Cnot+Rz)	0.085M	99.11

Method	Parameters	Medical-Mnist (%)
QViT [10]	1.0M	74.40
HQNN [5]	0.24M	99.97
Proposed(Cnot+Rx)	0.085M	99.98
Proposed(Cnot+Rz)	0.085M	99.99

Testing (increasing output classes)

4. Cifar100

No. of Classes	10	20	30	40	50	60	70	80	90	100
	Accuracy in Percentage									
QuEENet (CNOT+Rx)	86.70	70.9	65.67	58.09	55.18	52.52	49.96	48.04	47.19	45.18
QuEENet (CNOT+Rz)	83.60	69.45	62.60	55.43	54.66	52.77	49.77	48.19	46.22	43.93



References

1. Amila Akagic and Emir Buza. Lw-fire: A lightweight wildfire image classification with a deep convolutional neural network. *Applied Sciences*, 12(5):2646, 2022.
2. Zeineb Daoud, Amal Ben Hamida, and Chokri Ben Amar. Fireclassnet: a deep convolutional neural network approach for pif fire images classification. *Neural Computing and Applications*, 35(26):19069–19085, 2023.
3. Pankaj Pratap Singh, Nimish Grover, Prashansa Sharma, and Pooja Singhal. Utilizing convolutional neural networks (cnns) for the detection of smoke and fire through cctv camera surveillance. *Genze Int. J. Eng. Technol*, 2024.
4. Shubhangi Chaturvedi, Poornima Singh Thakur, Pritee Khanna, Aparajita Ojha, Yongze Song, and Joseph L Awange. Satellite image-based surveillance and early wildfire smoke detection using a multiattention interlaced network. *IEEE Transactions on Industrial Informatics*, 2025.
5. Arsenii Senokosov, Alexandr Sedykh, Asel Sagingalieva, Basil Kyriacou, and Alexey Melnikov. Quantum machine learning for image classification. *Machine Learning: Science and Technology*, 5(1):015040, 2024.
6. Hui Zhang, Qinglin Zhao, and Chuangtao Chen. A lightweight quantum self-attention model for classical data classification. *Applied Intelligence*, 54(4):3077–3091, 2024.
7. Monika Kabir, Mohammed Kaosar, Hamid Laga, and Ferdous Sohel. Lhqnn: sequential and non-sequential layered hybrid quantum neural networks for image classification. *Quantum machine intelligence*, 7(1):51, 2025.
8. Arsenii Senokosov, Alexandr Sedykh, Asel Sagingalieva, Basil Kyriacou, and Alexey Melnikov. Quantum machine learning for image classification. *Machine Learning: Science and Technology*, 5(1):015040, 2024.
9. Mahabubul Alam, Satwik Kundu, Rasit Onur Topaloglu, and Swaroop Ghosh. Quantum-classical hybrid machine learning for image classification (iccad special session paper). In *2021 IEEE/ACM International Conference On Computer Aided Design (ICCAD)*, pages 1–7. IEEE, 2021.
10. Hui Zhang, Qinglin Zhao, and Chuangtao Chen. A lightweight quantum self-attention model for classical data classification. *Applied Intelligence*, 54(4):3077–3091, 2024.



Conclusion

- A novel hybrid quantum-classical fusion model was proposed for Image Classification.
- QuEENet seamlessly integrates parameterized quantum circuits into a classical convolutional backbone.
- Our approach investigates the role of quantum circuit design in learning expressive features with reduced parameter overhead while maintaining/improving classification accuracy.
- QuEENet demonstrates the potential of expressive, hybrid quantum-classical designs for scalable vision tasks, offering a promising direction for efficient learning in low-resource quantum regimes.

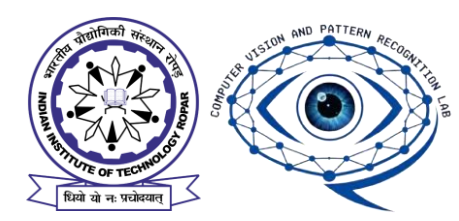

Thank You
